



# Cavity Sliders & Sliding Doors



NEW ZEALAND'S PREMIER CAVITY SLIDERS



# The Hallmark Advantage



**30+ YEARS**  
EXPERIENCE



Hallmark Group have been NZ's door experts for more than 30 years. That's a lot of experience behind your cavity slider!



**10 YEAR**  
WARRANTY

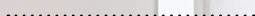

All Hallmark Cavity Sliders are backed by our 10 Year Warranty, giving you total peace of mind



**STRONG**  
BUILT TO LAST

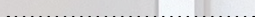

Hallmark Cavity Sliders are built to last. Our premium components are strong, designed to withstand years of rigorous use



**SMOOTH**  
RUNNING

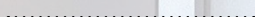

Our premium running gear rolls super-smooth and quietly for years



**NZ MADE**  
BY HALLMARK



Hallmark Cavity Sliders are made here. With total control over our production we can guarantee the highest of quality standards



**RENEWABLE**  
TIMBER

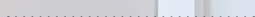

All timber components are renewable NZ Pine



# HALLMARK PREMIUM CAVITY SLIDERS

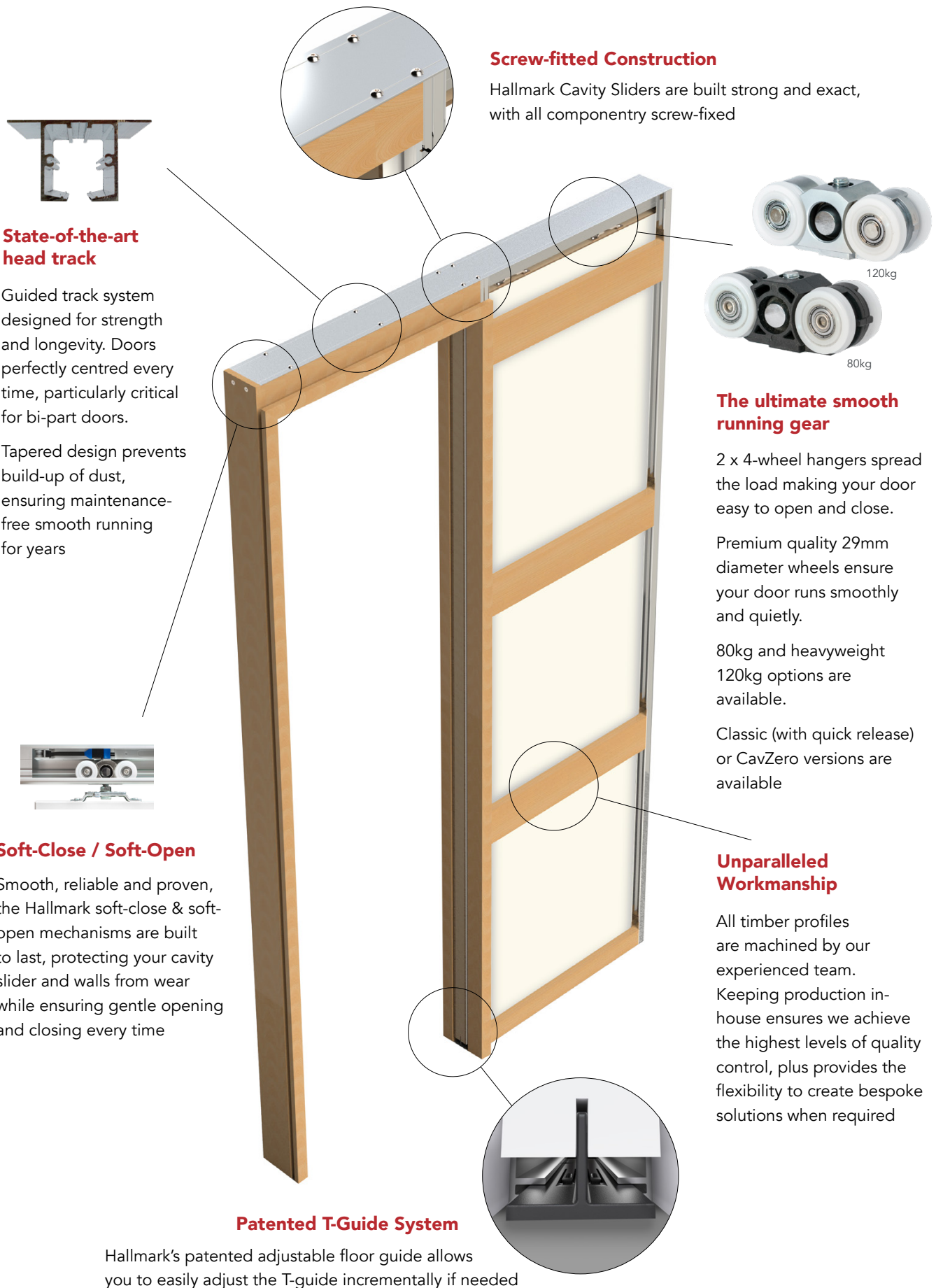

## State-of-the-art head track

Guided track system designed for strength and longevity. Doors perfectly centred every time, particularly critical for bi-part doors.

Tapered design prevents build-up of dust, ensuring maintenance-free smooth running for years

## Screw-fitted Construction

Hallmark Cavity Sliders are built strong and exact, with all componentry screw-fixed



## The ultimate smooth running gear

2 x 4-wheel hangers spread the load making your door easy to open and close.

Premium quality 29mm diameter wheels ensure your door runs smoothly and quietly.

80kg and heavyweight 120kg options are available.

Classic (with quick release) or CavZero versions are available

## Soft-Close / Soft-Open

Smooth, reliable and proven, the Hallmark soft-close & soft-open mechanisms are built to last, protecting your cavity slider and walls from wear while ensuring gentle opening and closing every time

## Unparalleled Workmanship

All timber profiles are machined by our experienced team. Keeping production in-house ensures we achieve the highest levels of quality control, plus provides the flexibility to create bespoke solutions when required

## Patented T-Guide System

Hallmark's patented adjustable floor guide allows you to easily adjust the T-guide incrementally if needed

# Hallmark CavZero®

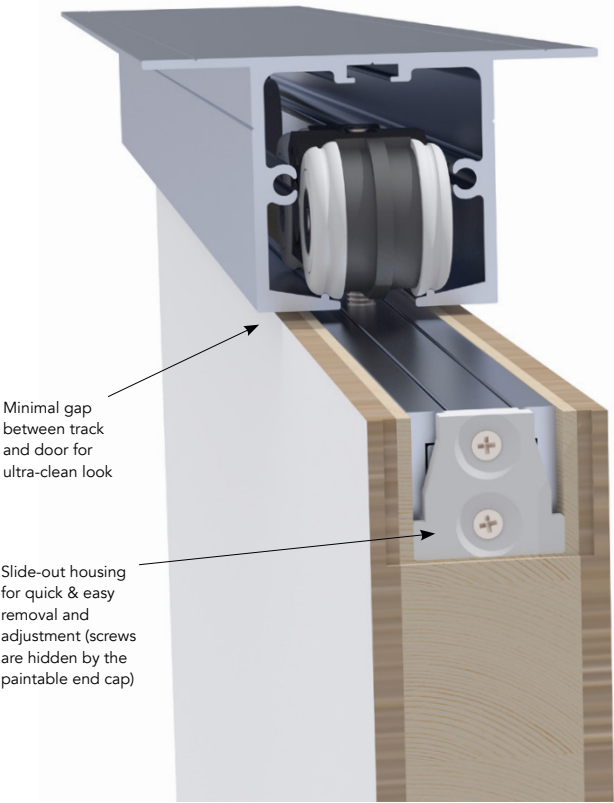

Exclusive to Hallmark, this world-class slider system provides two key benefits; the ability to remove the door without removing trims or architraves which eliminates any chance of paint damage, and a minimal space between the top of the door and head track, resulting in beautiful clean lines, particularly in a full height application.

CavZero® can be added to any Hallmark cavity slider unit in any size. Your Hallmark door leaf will arrive with the required routs in the top of the door to accommodate the CavZero® components.

The CavZero® housing is screw-fixed into a rebate in the top of the door. To remove the door simply lift the end cap, undo the screws and pull out the slide. As easy as that!



Paintable end cap



CavZero cavity slider, in No Closing Jamb configuration



# Hallmark Classic

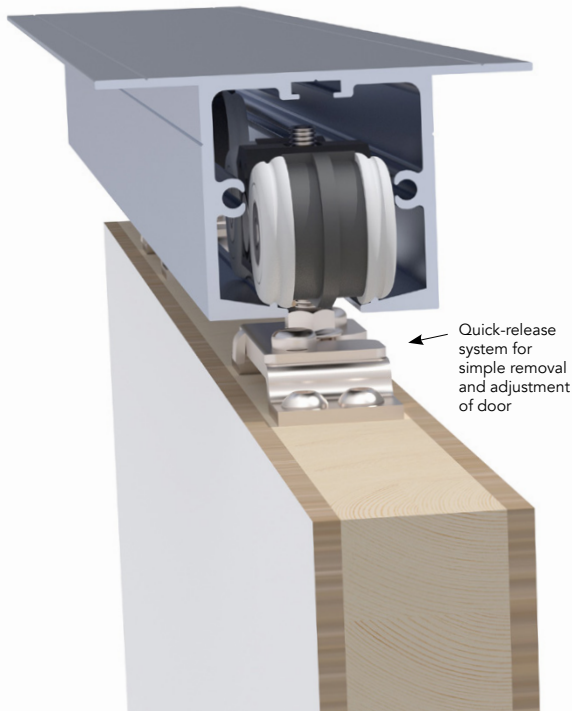

This is our classic wheel carriage system; tried, tested and beautiful in its simplicity.

Screw fastened to the top of the door, the Classic is a robust slider wheel unit with a quick-release system, allowing the door to be easily removed from the track.

The hanging bracket is hidden from view behind trims or architraves.

## CONFIGURATION OPTIONS

Below are the more common configurations, however we can custom-make to most design requirements. While the drawings show standard height cavity sliders, all configurations are also available in full-height, and in either 90mm, 140mm stud, or to your custom requirements.

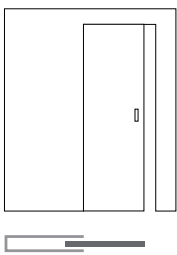

Single

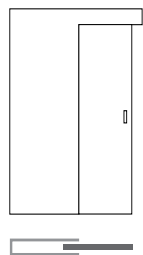

No Closing Jamb

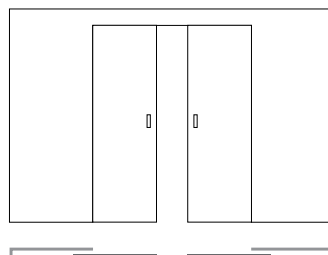

Bi-Parting

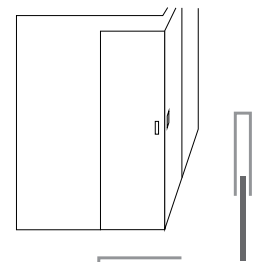

Right Angle (corner meeting)

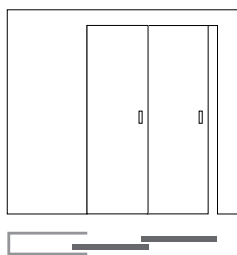

Double Stacking

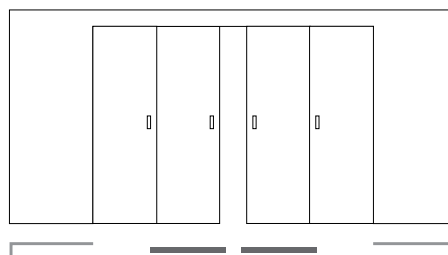

Bi-Part Double Stacking

## JAMB OPTIONS

### TIMBER GROOVED JAMB



Grooved jambs have rebates to allow for wallboard linings to slot in. Single or double grooved options are available, and we can machine the jambs to any specialist lining requirements. See profiles on following pages.

### TIMBER ARCHITRAVE



Architrave jambs are flat jambs that allow for architraves to be attached over the top. See profiles on following pages.

### URBINOS™ ALUMINIUM ARCHITRAVE



Urbinos is Hallmark's premium aluminium jamb system. This strong two-piece aluminium jamb suits a range of wall thicknesses, resulting in robust longevity matched with a minimalist appearance. See profiles on page 18.

### CAVZERO PLASTERBOARD RETURN



The CavZero plasterboard return concealed jamb system enables clean lines for a sleek modern finish.

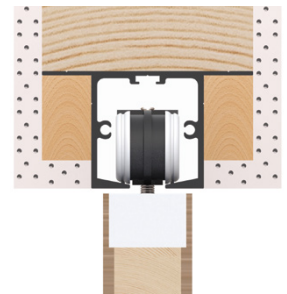

### CUSTOM SOLUTIONS

Hallmark are experts in manufacturing doorsets. We understand that each project is unique and have the ability to custom-make doors and jambs, with specialised timber trims we produced in-house. Our team have a wealth of experience so call us to discuss any custom solutions required.



## STANDARD HEIGHT & FLUSH CEILING FINISH

### STANDARD HEIGHT FINISH



The Standard Height cavity slider is used in a typical doorway where the wall wraps around the top of door.

A full range of jamb options are available (see previous page), and either Classic or CavZero systems can be used.

### FLUSH CEILING FINISH



For beautiful uninterrupted clean lines, the Flush Ceiling finish has the slider running the full height from floor to ceiling.

Our CavZero system is used for an elegant look with minimal gap between door and ceiling, and to allow easy removal of door if required.

## OPENING / CLOSING ACTION



SOFT CLOSE

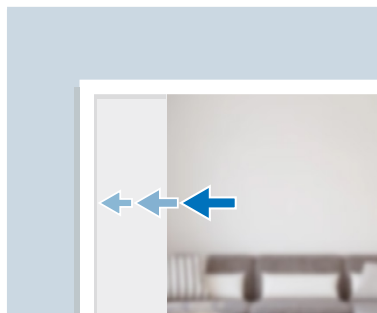

SOFT OPEN

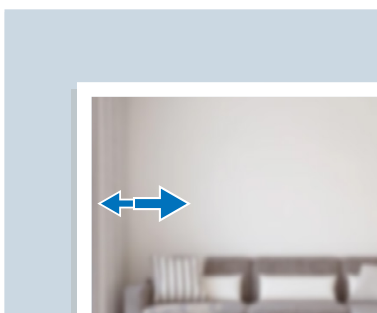

JEXIS OPENER

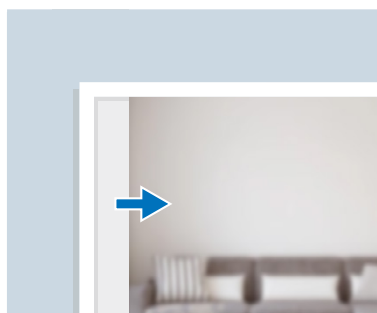

PROTRUDING

Hallmark's Soft Close & Soft Open units (see page 21) are available on any configuration. The Soft Close automatically brings your door to a smooth and quiet stop when closing, and the Soft Open prevents the door from slamming against the back of the pocket when opening.

A Jexis Opener allows the door to spring from the pocket from the flush position. A gentle push on the end of the door activates the spring-loaded opener and the door pops out of the pocket ready to be closed.

A protruding opening is where the opened door protrudes, usually by 100mm, to allow for a handle to be used to close the door.

Hallmark's CavZero system offers the advantage of being able to fit or adjust any of these systems without having to remove architraves, which also means no painting required!

## NEW ZEALAND'S BEST RANGE OF DOORS

### PAINT QUALITY, GLAZED AND GROOVED DOORS

Hallmark is a leading New Zealand door manufacturer with the largest premium door offering in NZ, a range too extensive to fit in this brochure! (visit [www.hallmarkgroup.co.nz](http://www.hallmarkgroup.co.nz) to see the full range).

These include standard doors, doors with vision panels, grooved doors, and a range of beautiful wood veneer doors - all of which can be used with our cavity slider systems.

All doors are available in a range of sizes, and as either Honeycomb-core, Solid-core or Polystyrene-core, providing a range of acoustic barrier properties.

**PREMIUM**  
**4.75mm**  
**SKINS**

Hallmark's high-tech precision manufacturing process and 4.75mm premium door skins stand the brand apart from lower quality alternatives.

Hallmark doors come pre-routed for our cavity slider systems so there's no messing about on-site, and custom routing for hardware is also offered.



Flush ceiling bi-parting glazed cavity slider with CavZero system



Paint quality single cavity slider





## VENEER DOORS

Hallmark has its own veneer slicing and processing facility. We offer a complete veneer solution, producing both veneer panels and veneer doors, ensuring an accurate match between your panels and doors.

We offer an extensive selection of natural, sustainably-sourced, timbers including a NZ Native Range, Exotic Species Range, and Recon Range. See our website to select the ideal species for your project.



Bi-parting double-stacking veneer sliding doors

## ALUMINIUM FRAMED GLAZED SLIDERS

Also available are aluminium-framed glazed sliders. This is a classy aluminium-framed unit with no visible screws or fixings. It can be supplied in natural anodised finish, or powder-coated to almost any colour to suit your design.



# WALL-MOUNTED SURFACE SLIDING DOORS

Hallmark also produce a wall-mounted surface sliding door system. Installation is simple and our head track comes with matching end caps to conceal the track, resulting in a versatile and tidy surface slider.

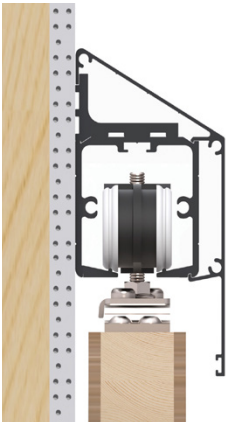

Wall-Mounted Sliding Door, angled top

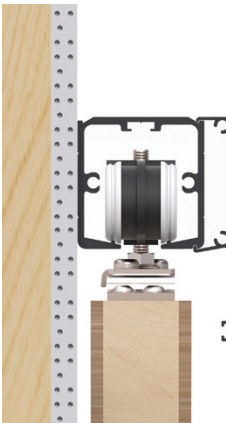

Wall-Mounted Sliding Door, flat top



Wall-Mounted Sliding Door, angled top



Wall-Mounted Sliding Door, flat top



# THE ULTIMATE SMOOTH-GLIDE TRACK

Hallmark's high-grade extruded aluminium track system ensures your door will glide smooth and straight every time. We insist on the highest quality NZ-made extrusions for strength and longevity. A unique feature of Hallmark's patented T-Guide is its adjustability, allowing the guide to be moved incrementally left or right for absolute fine-tuning to allow for any installation variances.

## 90mm Standard Single Track System

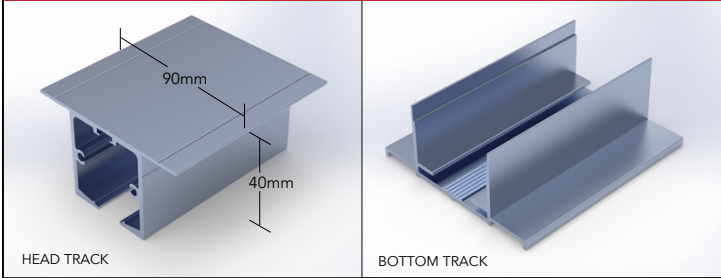

## 90mm Soft Close Single Track System

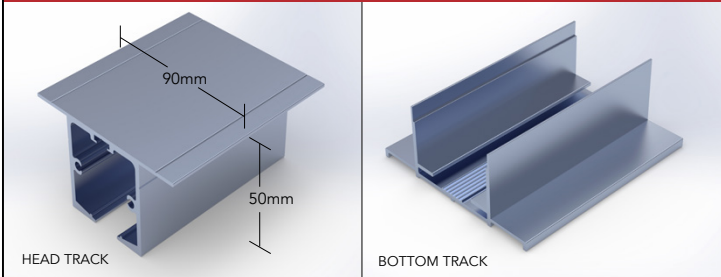

## 90mm Single Flush Ceiling System

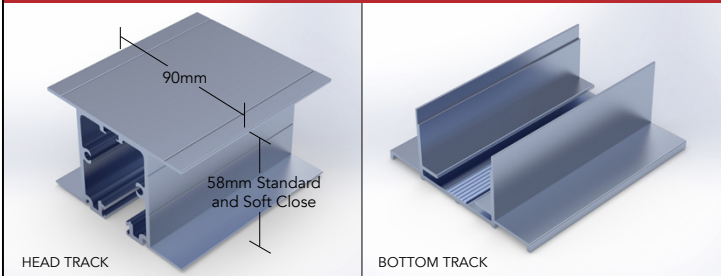

## 140mm Single Track System

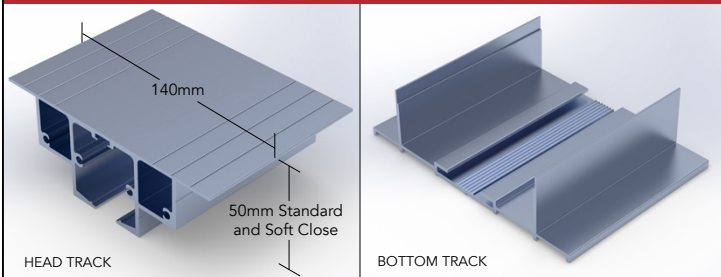

## 140mm Double Stacking Track System

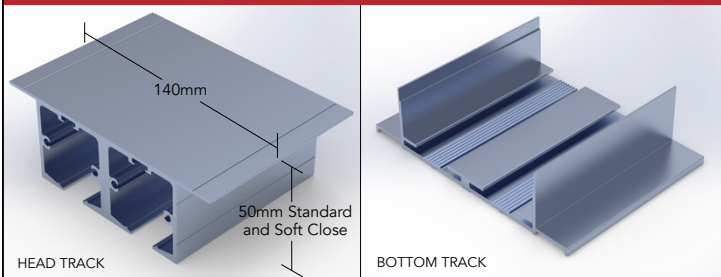

## THE HALLMARK T-GUIDE

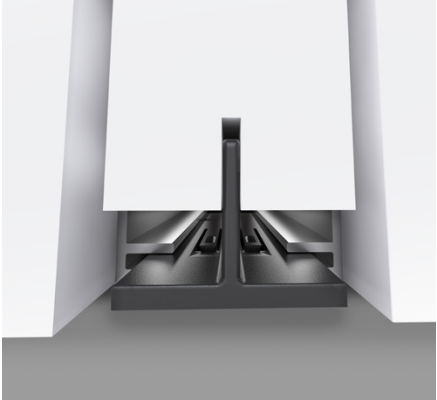

Hallmark's patented T-Guide system provides sideways adjustment at the base in 2mm increments. When combined with adjustment to the wheel carriage at the head of the door, this gives provision for any natural movement or bow of the door or pocket, ensuring the door slides smoothly without sideways scuffing.

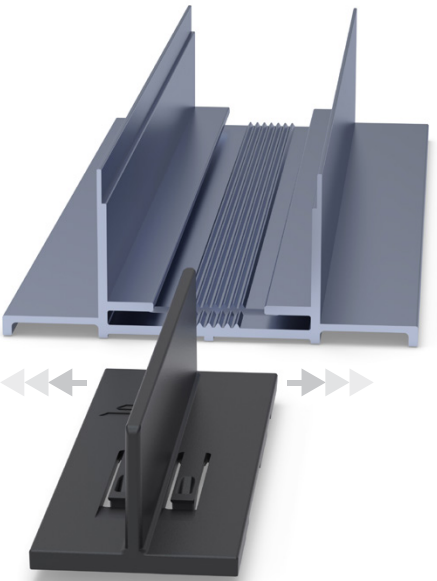





## CavZero® Full Height - Flush Ceiling Finish - 90mm Stud

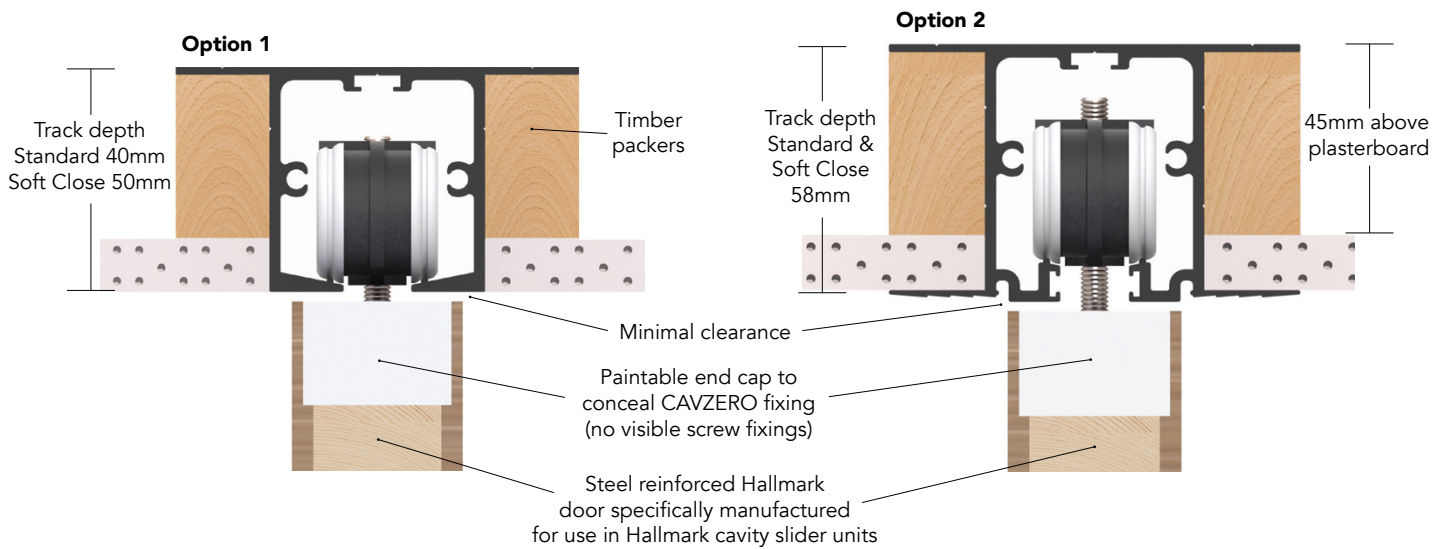

## Classic Standard Height - 90mm Stud

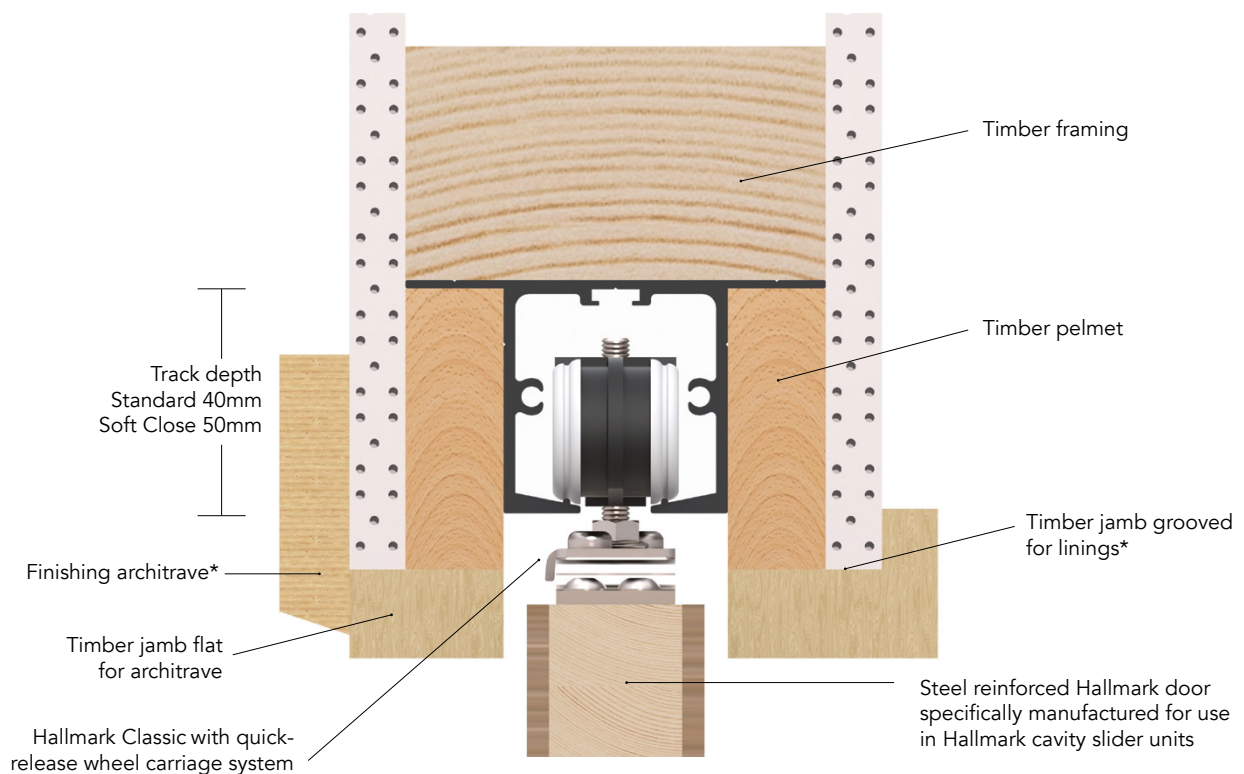

\* Architrave & grooved options both shown in this drawing

**140mm STANDARD HEIGHT & FULL HEIGHT**

**CavZero® Standard Height - 140mm Stud**

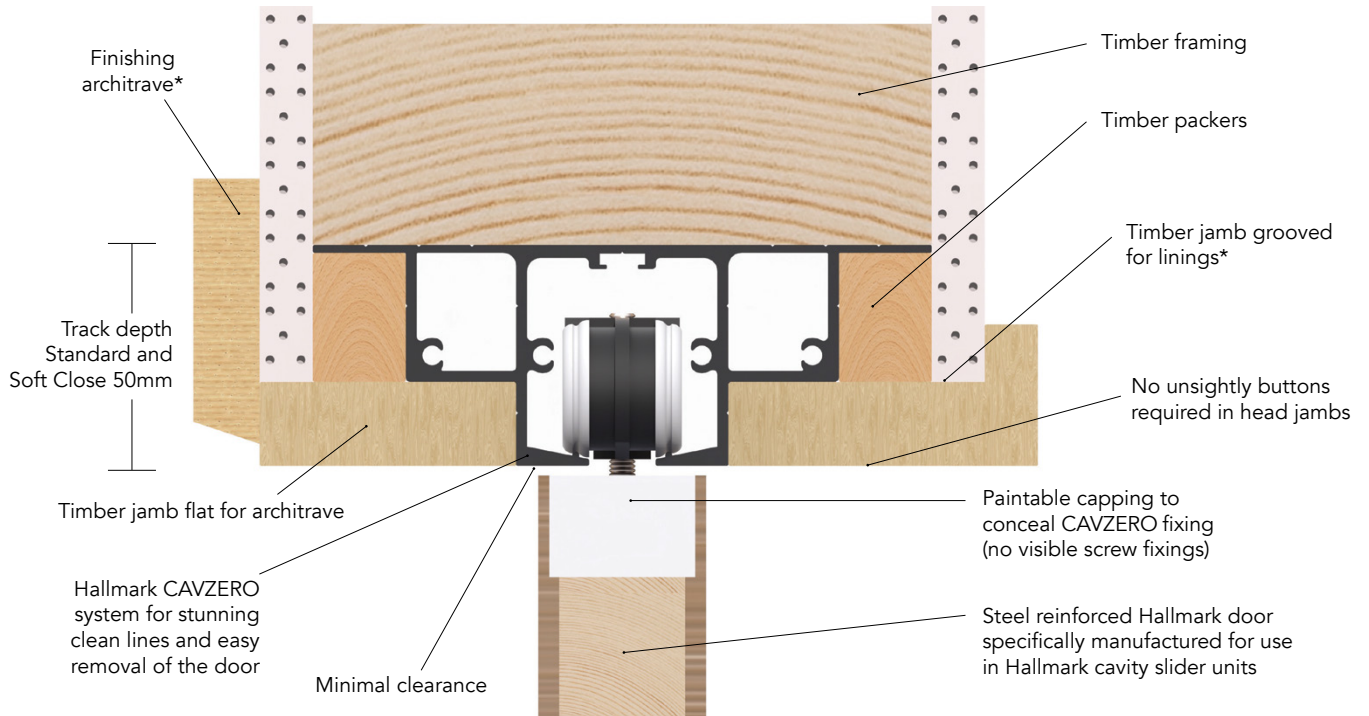

*\* Architrave & grooved options both shown in this drawing*

**CavZero® Plasterboard Return - 140mm Stud**

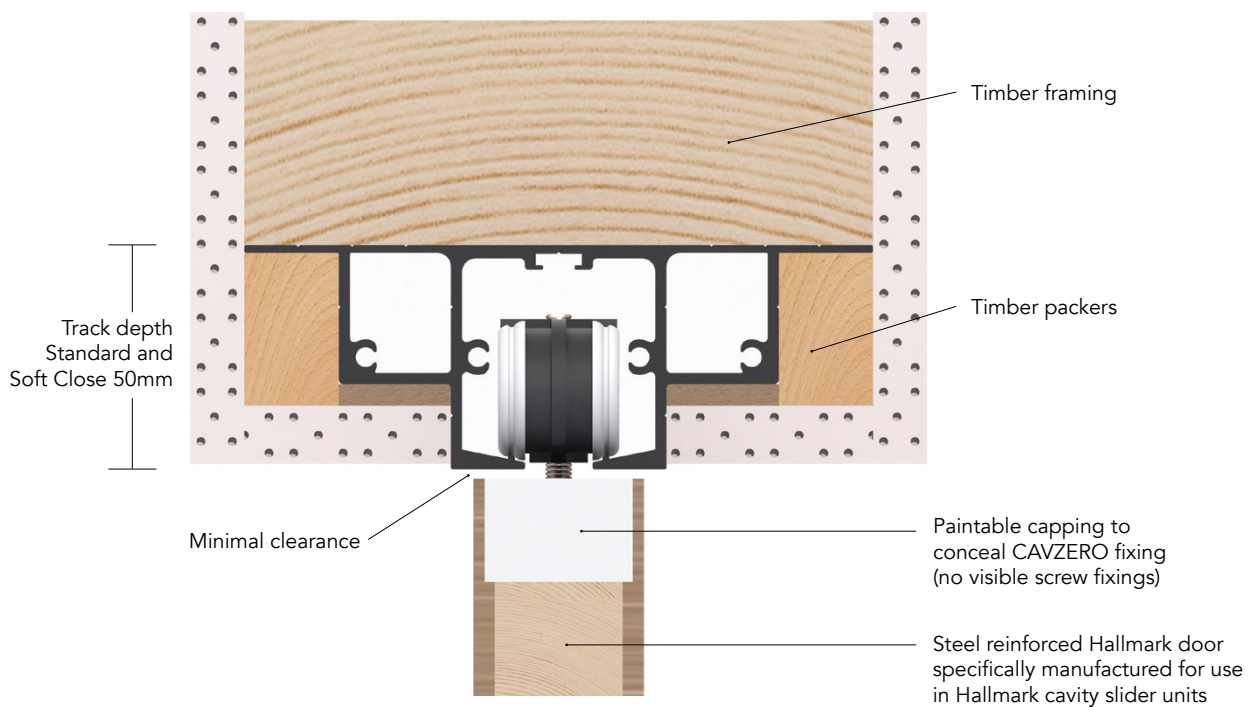



## CavZero® Full Height - Flush Ceiling Finish - 140mm Stud

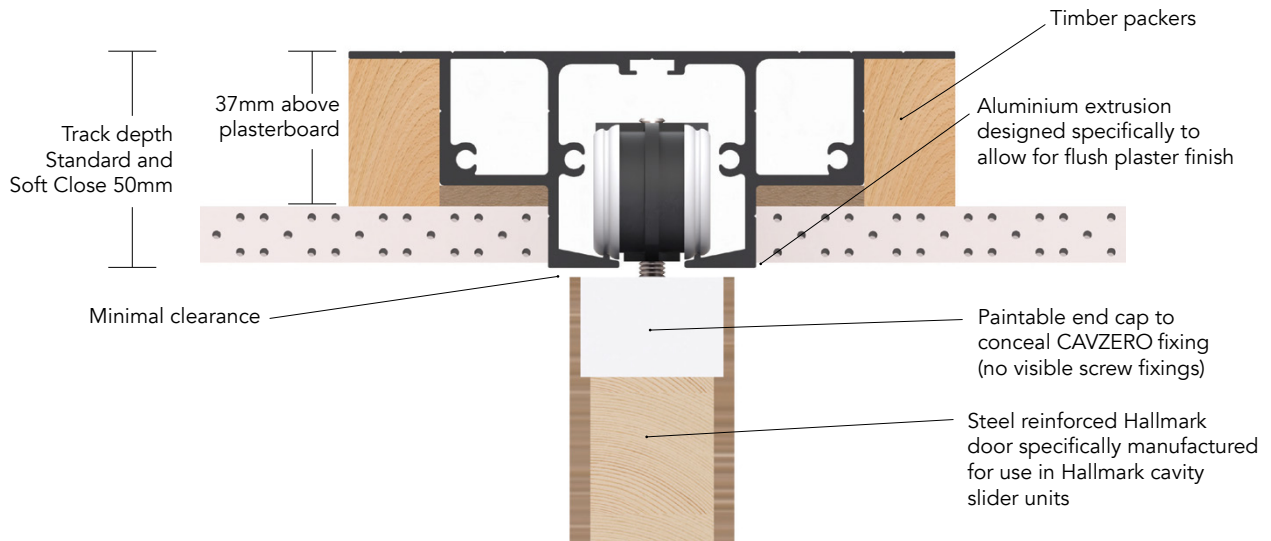

## Classic Standard Height - 140mm Stud

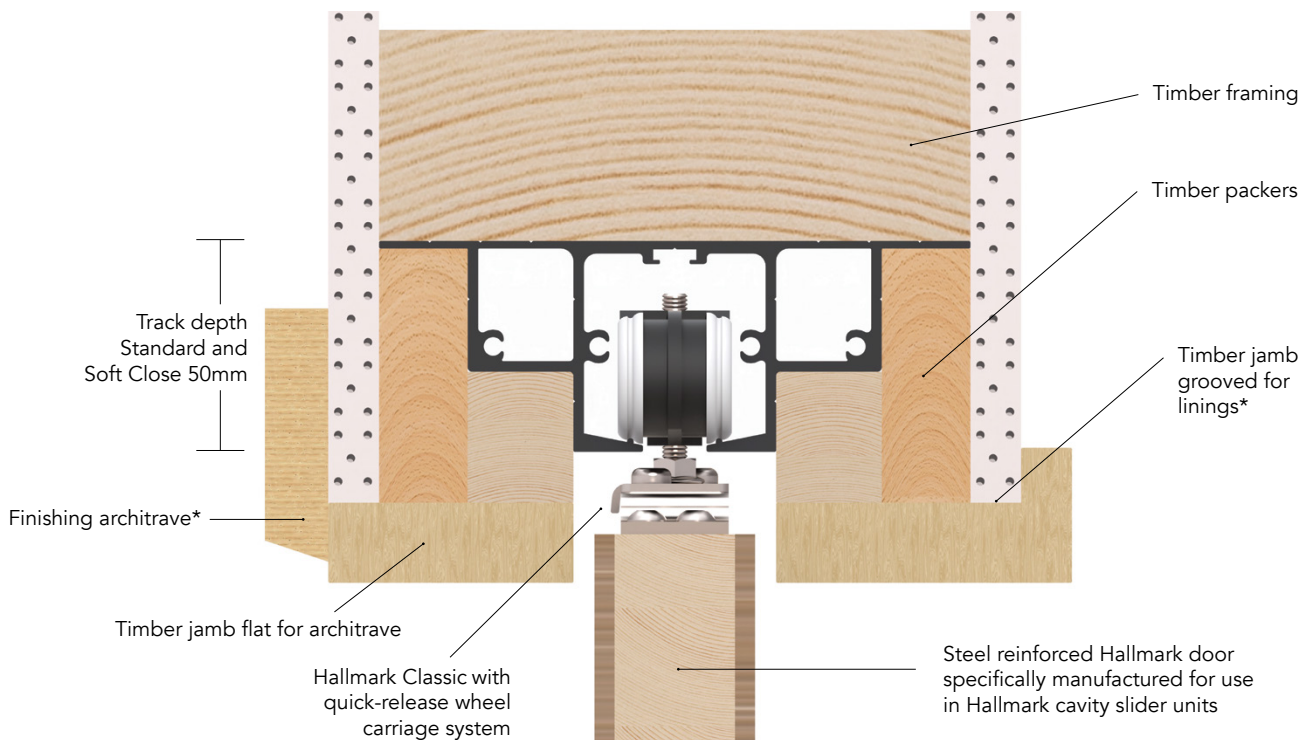

\* Architrave & grooved options both shown in this drawing

**140mm DOUBLE STACKING CAVITY SLIDERS**

**CavZero® Standard Height - Double Stacking - 140mm Stud**

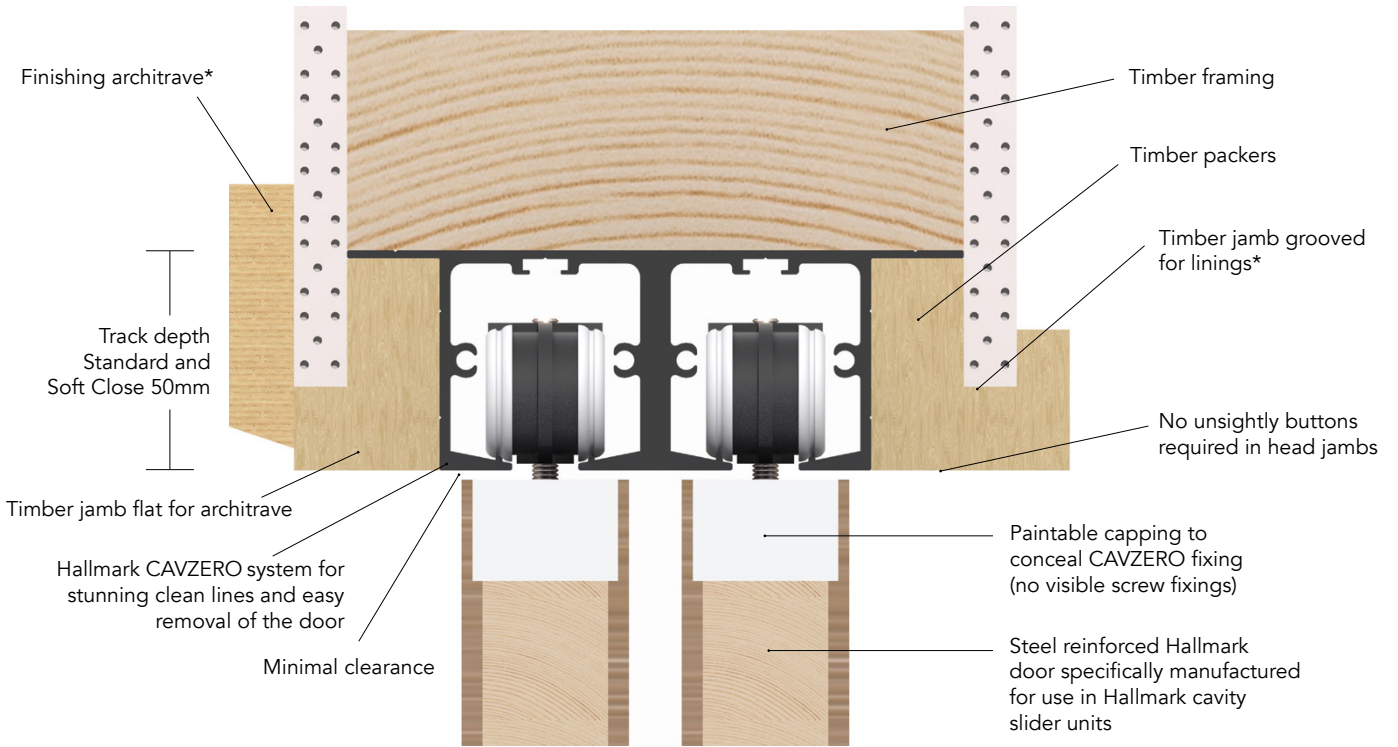

\* Architrave & grooved options both shown in this drawing

**Classic Standard Height - Double Stacking - 140mm Stud**

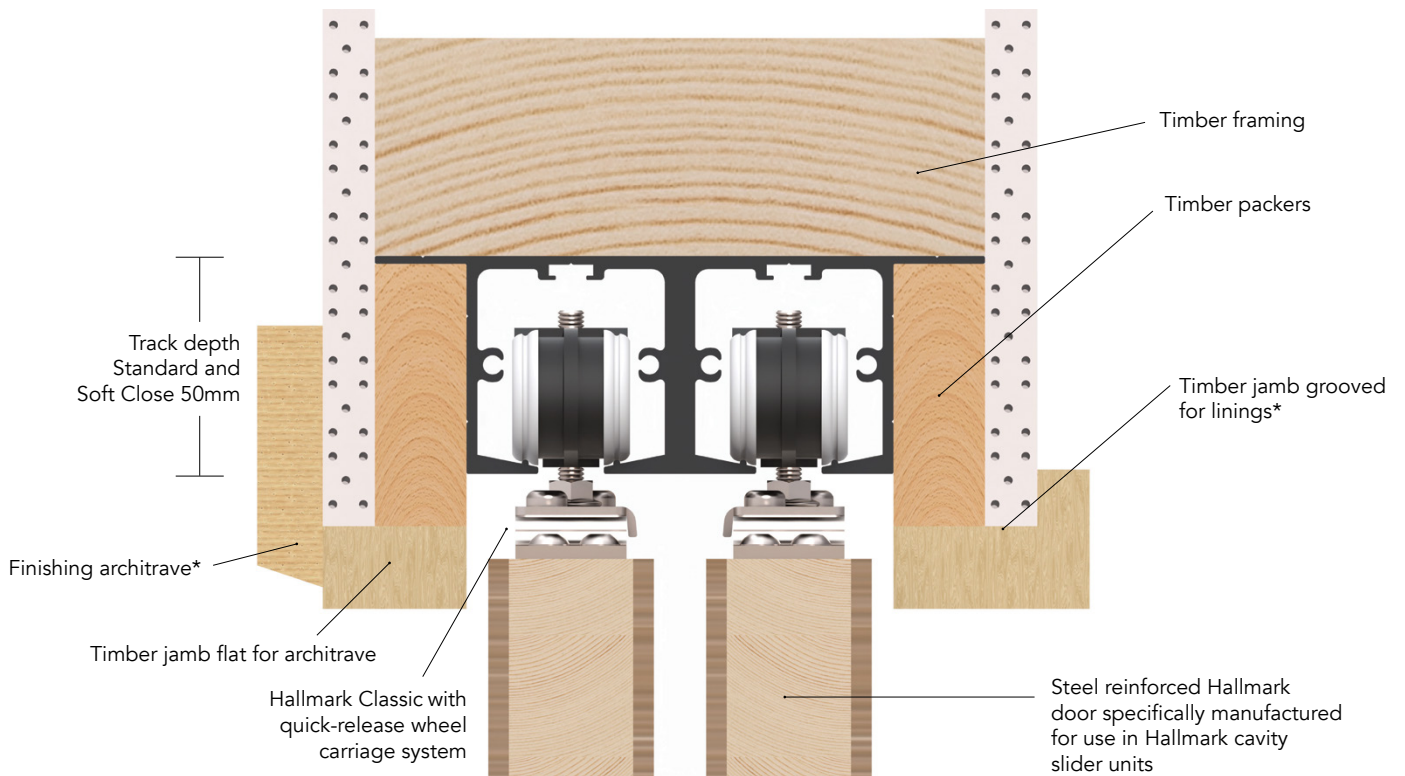

\* Architrave & grooved options both shown in this drawing



## SPECIALTY SIZE & STRENGTH OPTIONS

Our framing system caters for extra-wide or extra-high units, with the ability to insert steel reinforcement when additional strength is needed. We offer premium aluminium extrusions with one-cell, two-cell, or three cell sections and a range of reinforcement options depending on strength integrity requirements.

### EXTRA-STRENGTH POCKET OPENING JAMBS

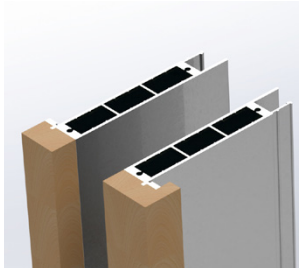

Triple cell pocket opening

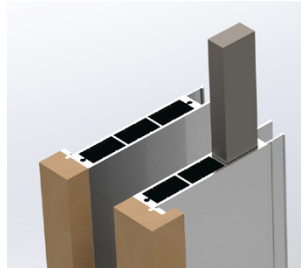

Triple cell pocket opening with steel insert

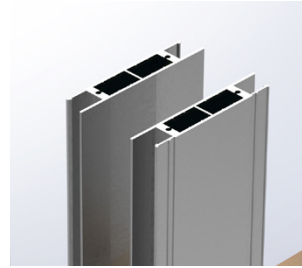

Double cell mid stud

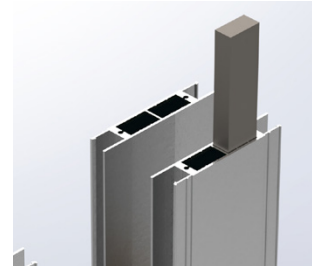

Double cell mid stud with steel insert

### SOLID PLYWOOD CAVITY POCKETS

Plywood cavity panels are available to create solid cavity walls to allow for fixings. Available in single-side or double-side.

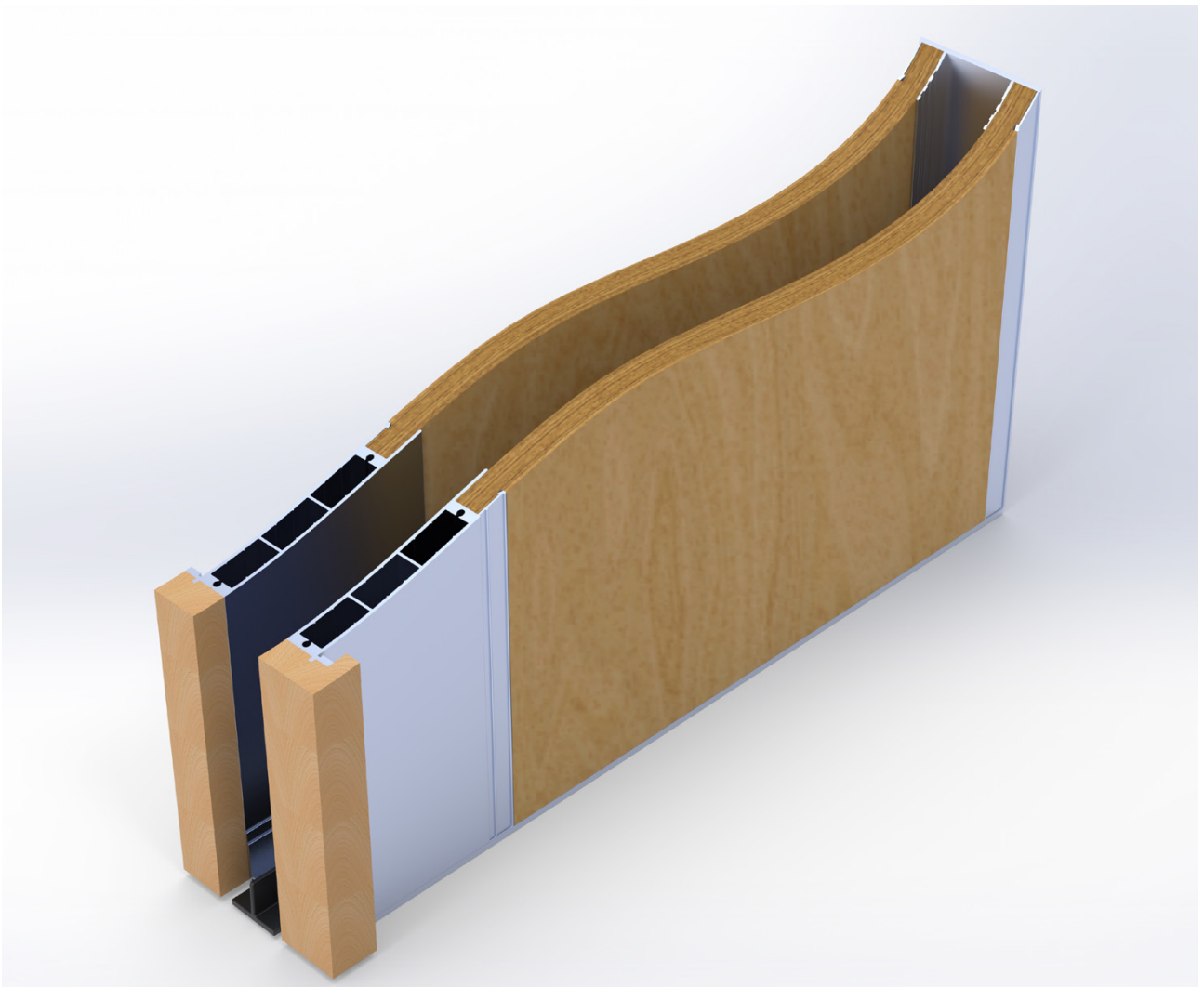

# FLUSH PLASTER FINISH

## Flush Plaster Finish 90mm Plasterboard Return

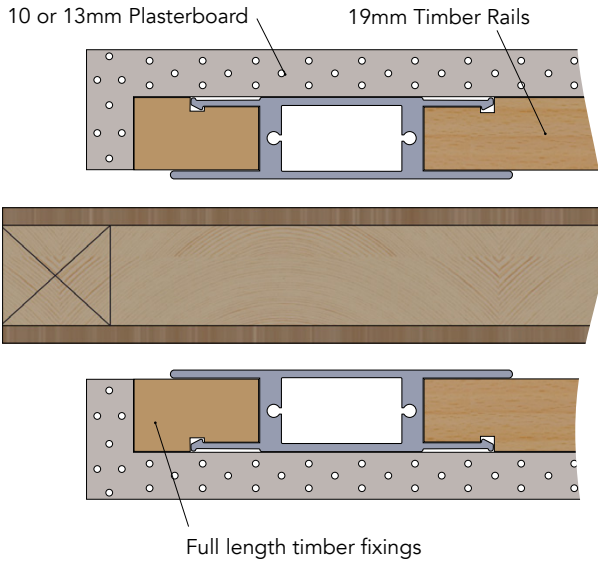

## Flush Plaster Finish 140mm Plasterboard Return

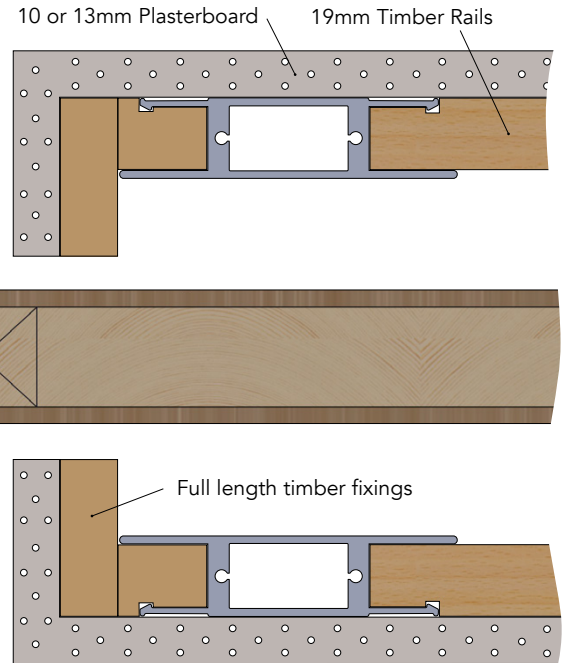

## Flush Plaster Finish 90mm Right Angle Wall

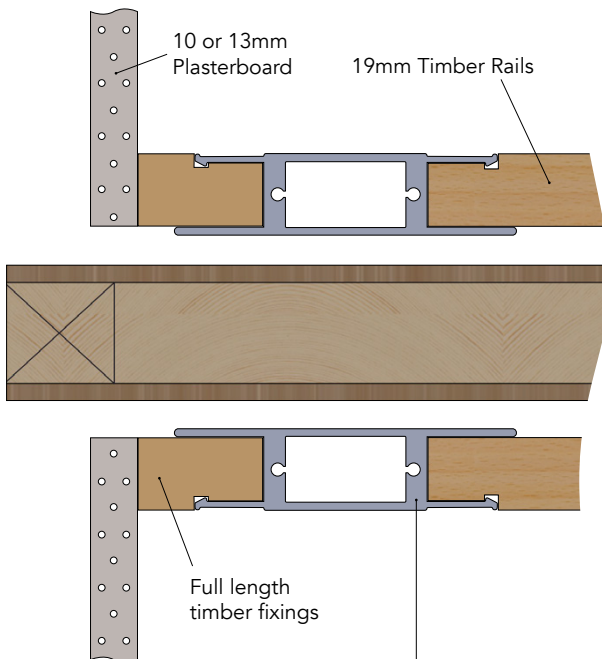

## Flush Plaster Finish 140mm Right Angle Wall

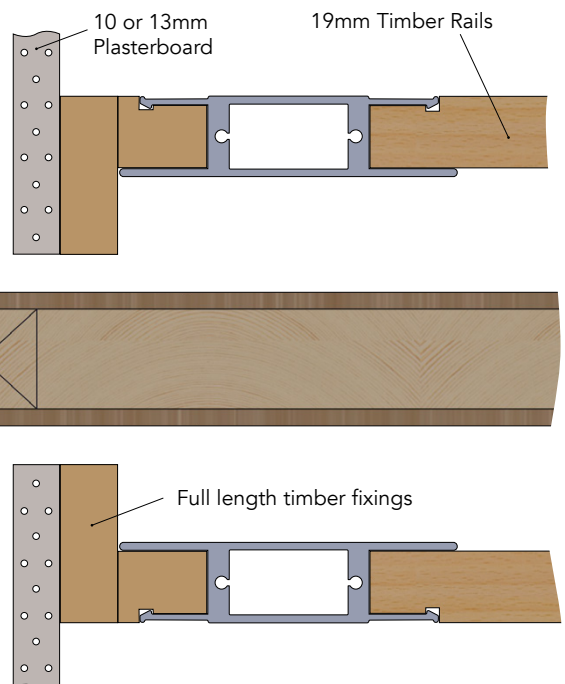

Extra-strength opening jambs (on all plasterboard return units)



**Flush Plaster Finish**  
**90mm Parallel Wall**

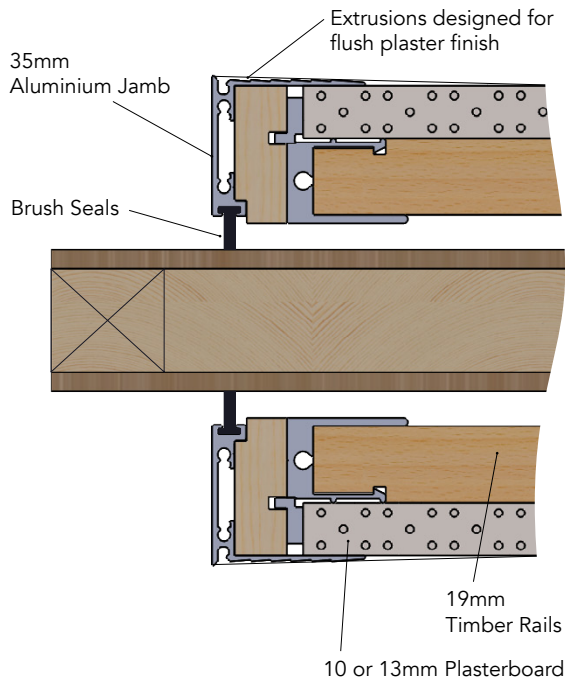

**Flush Plaster Finish**  
**140mm Parallel Wall**

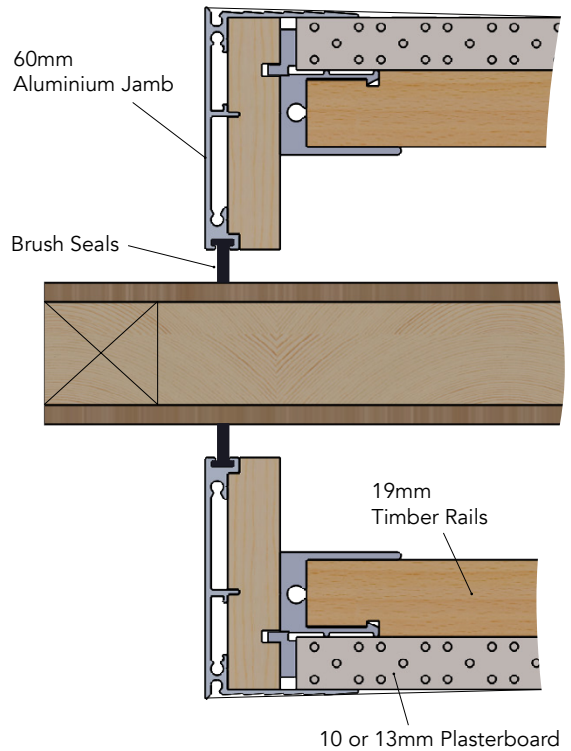

# Urbinos®

Our Urbinos® Flush Finish system includes a range of profiles to create a beautiful flush finish to your cavity slider unit. Hallmark has developed a range of quality proprietary aluminium profiles to provide a flush or plaster finish for most cavity slider configurations.

The Urbinos® system has a clip-on architrave option which clips easily and securely to the clip-on architrave jamb profile. These are available powdercoated, anodised or etch primed for paint finish

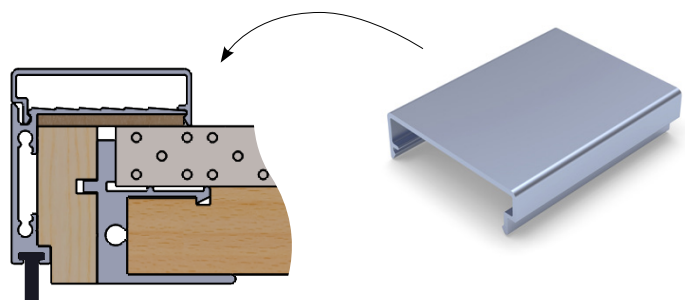

- All Hallmark Cavity Slider units have 48mm openings as standard
- All Hallmark Cavity Slider doors are 35mm thick including premium 4.75mm skins
- All Hallmark Cavity Slider profiles are designed to accommodate varying wall linings

# ALUMINIUM JAMBS

## Flush Plaster Finish 90mm Parallel Wall

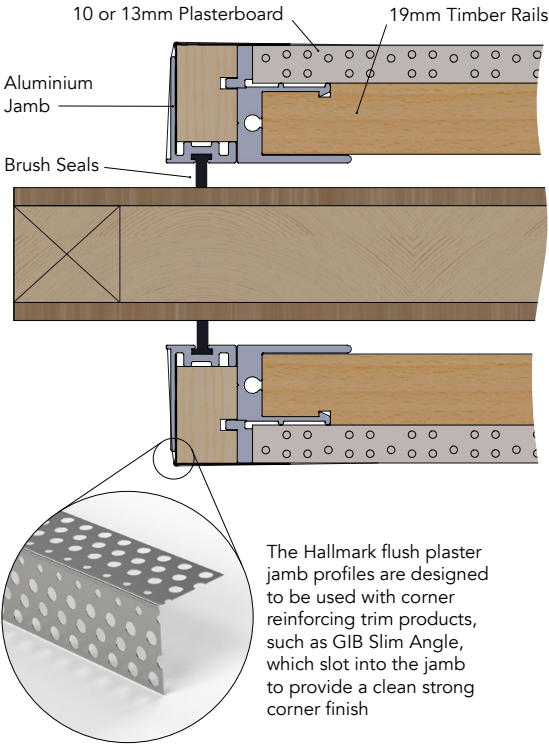

## Flush Plaster Finish 140mm Parallel Wall

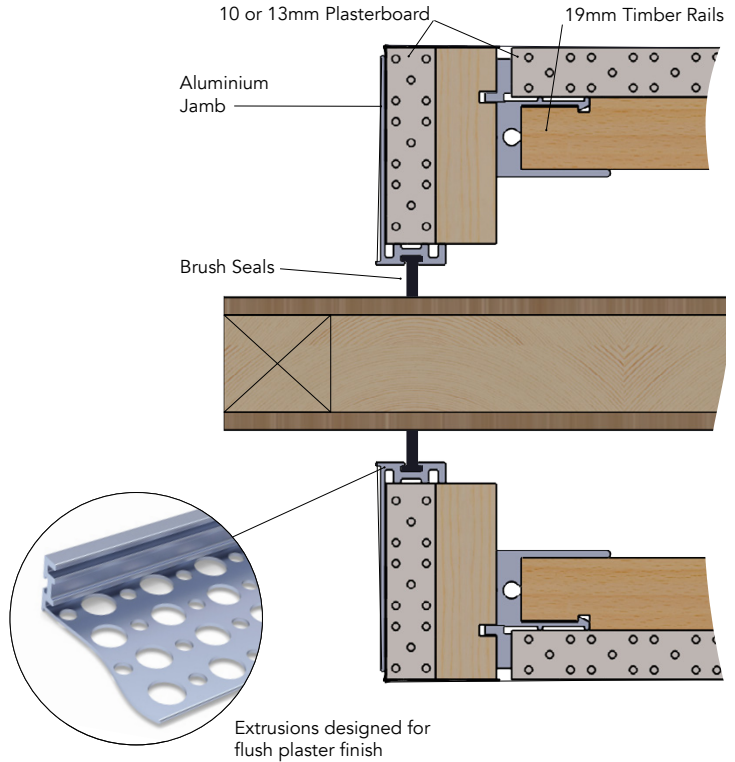

## Flush Plaster Finish 90mm Right Angle Wall

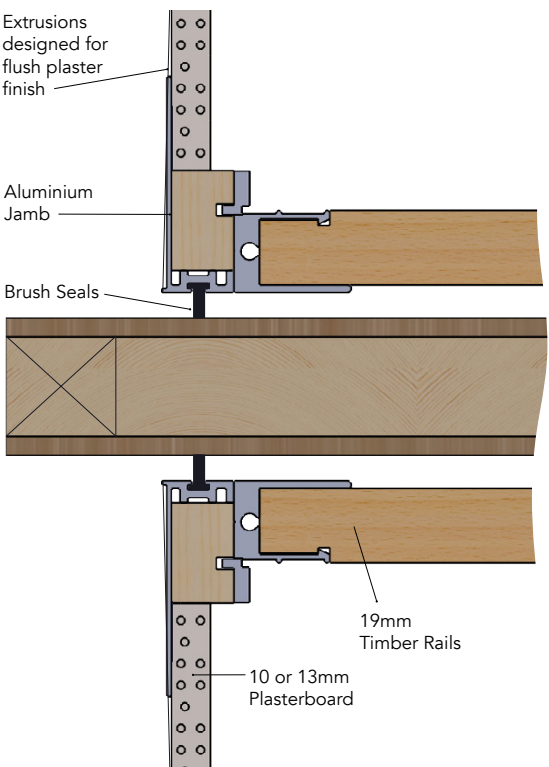

## Flush Plaster Finish 140mm Right Angle Wall

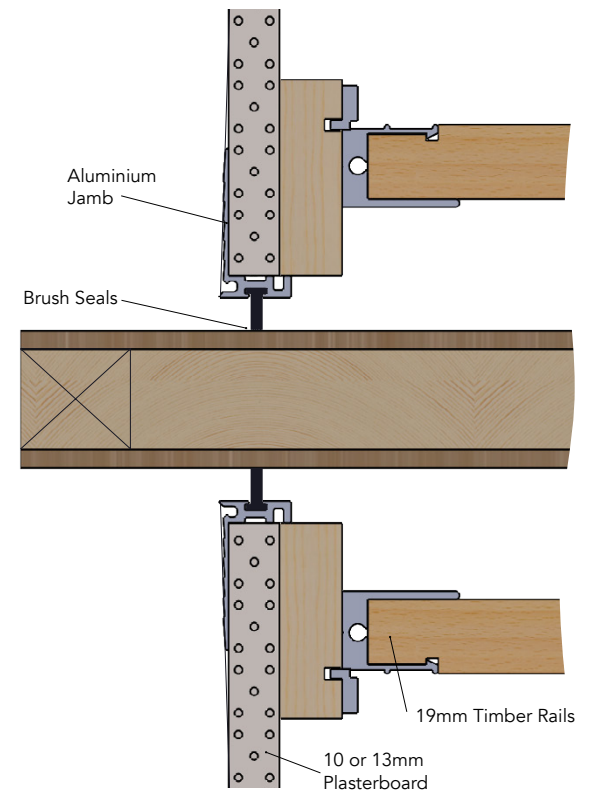

## THE HALLMARK SOFT CLOSE UNIT



Soft Close cavity sliders provide a beautiful finish to any Hallmark cavity slider unit. You simply pull the door to the closed or open position and the mechanism catches to the door, bringing it to a gentle stop. All Hallmark Group cavity slider configurations are available with Soft Close and/or Soft Open functions. Hallmark Soft Close units are designed to suit a range of door weights from 15kgs to 80kgs.

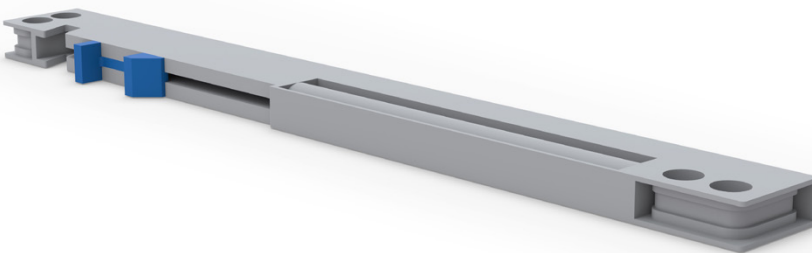

The hydraulic cartridge is hidden away inside the head track. The Soft Close wheel carriage has a tab which fits into the blue collector brackets of the cartridge, activating the hydraulic closer to bring the door to a smooth and silent close.

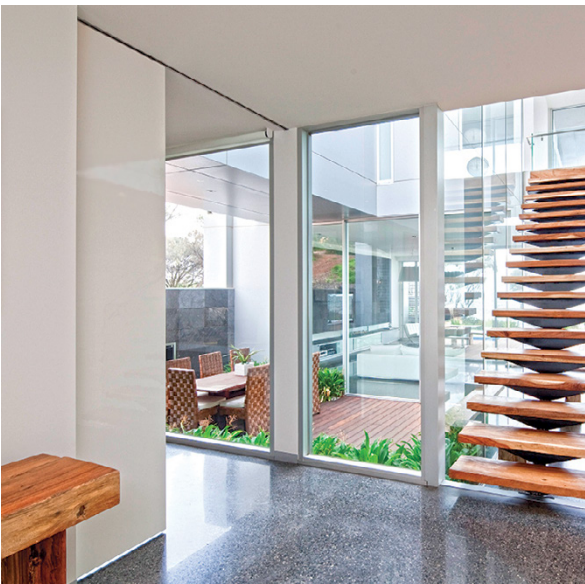



## TRIM SIZE FORMULA

### Classic

#### Trim Height

- Hallmark Classic:  
**Door Height + Floor Clearance + 70mm**
- Hallmark Classic with Soft Close:  
**Door Height + Floor Clearance + 80mm**

(Standard floor clearance is 25mm)

#### Trim Width

- Single: **Door Width x 2 + 35mm**
- Double: **Door Width x 4 + 20mm**

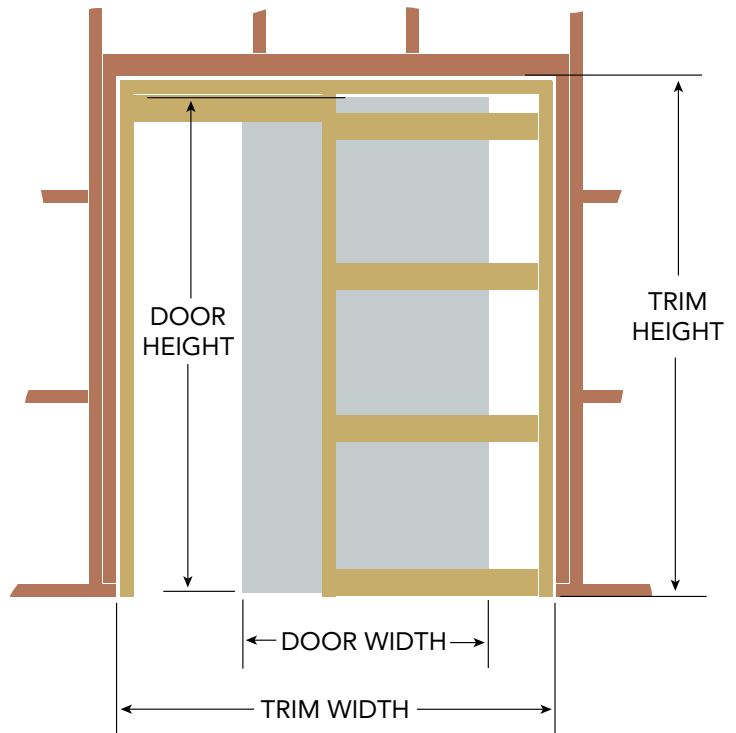

### CavZero

#### Trim Height

- Hallmark CavZero:  
**Door Height + Floor Clearance + 50mm**
- Hallmark CavZero with Soft Close:  
**Door Height + Floor Clearance + 60mm**
- Full height detail track:  
**Door Height + Floor Clearance + 70mm**

(Standard floor clearance is 25mm)

#### Trim Width

- Single: **Door Width x 2 + 35mm**
- Double: **Door Width x 4 + 20mm**

#### How to specify (example)

Product:	Hallmark Classic Cavity Unit
Single/Double:	Single
Door type:	Hallmark Ultimate Cavity Door
Door spec:	2400 x 910 x 34.5 Polystyrene core
Jamb type:	Clear pine flat for architraves
Framing:	90mm timber
Wall linings:	10mm
Door finish:	Paint quality
Location:	Family room
Gear type:	Hallmark Guided 80kg track system
Hardware:	Windsor 5261 square flush pull



## *Our Promise to You*

*All Hallmark cavity sliders are produced from start to finish in a precision factory environment.*

*Unlike other cavity unit manufacturers, we produce all our own timber components in our factory, giving us complete control and flexibility over the entire process. Our rollers, aluminium components and soft close system have been engineered to our specifications and have passed extensive cycle testing.*

*We have a fully independent manufacturing facility set up for the production of cavity sliders units. This includes the stocking of standard size units so we can ship to our customers on a daily basis.*

*At Hallmark we're all about the customer experience. We're focused on giving our customers a seamless and stress-free experience from the quoting stage right through to after sales service. Should we ever have an issue we don't stuff around pointing the finger, we just get in and make it right.*



